

DJ Series Butterfly Valves



Standard Product Range

Standard		ASME		EN				JIS			
Pressure		150/200 psi		PN10		PN16		10K		16K	
Connection		Wafer	Lugged	Wafer	Lugged	Wafer	Lugged	Wafer	Double Flanged	Wafer	Double Flanged
Nominal size	Product code	150/200 DJ *1	150/200 DJL *1	PN16DJ	PN16DJL	PN16DJ	PN16DJL	10DJ	10DJF *2	16DJ	16DJF *2
	inch	mm									
2	50	●	●	●	●	●	●	●		●	—
2½	65	●	●	●	●	●	●	●		●	—
3	80	●	●	●	●	●	●	●		●	—
4	100	●	●	●	●	●	●	●	●	●	●
5	125	●	●	●	●	●	●	●	●	●	●
6	150	●	●	●	●	●	●	●	●	●	●
8	200	●	●	●	—	●	●	●	●	●	●
10	250	●	●	●	—	●	●	●	●	●	●
12	300	●	●	●	—	●	●	●	●	●	●
14	350	●	●	●	—	●	●	●	●	●	●
16	400	●	●	—	—	●	●	●	●	●	●
18	450	●	●	—	—	●	●	●	●	●	●
20	500	●	●	—	—	●	●	●	●	●	●
22	550	—	—	—	—	—	—	—	●	—	●
24	600	●	●	—	—	●	●	●	●	●	●

● : Available

* 1 : 200 psi for size 2 to 12, 150 psi for size 14 to 24

* 2 : Not shown in this catalog

Explanation of Product Code

G - PN16 DJ L U E

① ② ③ ④ ⑤ ⑥

① Valve operation

- NoneLever handle
- GGear
- VGVertical gear
- BType B pneumatic actuator
- BSType BS pneumatic actuator
- FAType FA pneumatic actuator
- FASType FAS pneumatic actuator
- EXS110/200 ...Type EXS KELMO® electric actuator
- EXC110/200...Type EXC KELMO® electric proportional control actuator

② Class

- 150..... ASME 150 psi
- 200..... ASME 200 psi
- PN16... EN1092 PN 16
- 10..... JIS 10K
- 16..... JIS 16K

③ Valve material and design

- DJ..... Ductile iron DJ series
- *Cast iron for JIS10K, Size 350-600
- FDDJ.... Ductile iron for JIS10K, Size 350-600 (Option)

④ Connection

- None.... Wafer
- L..... Lugged
- F.....Double flanged

⑤ Disc material

- None.... Ductile iron (Ni-plated)
- U..... 304 stainless steel
- M..... 316 stainless steel
- A..... Aluminum bronze

⑥ Seat material

- None.... NBR (Buna-N)
- E..... EPDM

This catalog uses MPa, a SI unit, for indication of pressures. For readers' convenience, however, kgf/cm² is also used as an additional information.

KITZ DJ Series Butterfly Valves

Thorough pursuit of functions required for butterfly valves
Variety of product ranges to comply with customers' requirements

Design Features

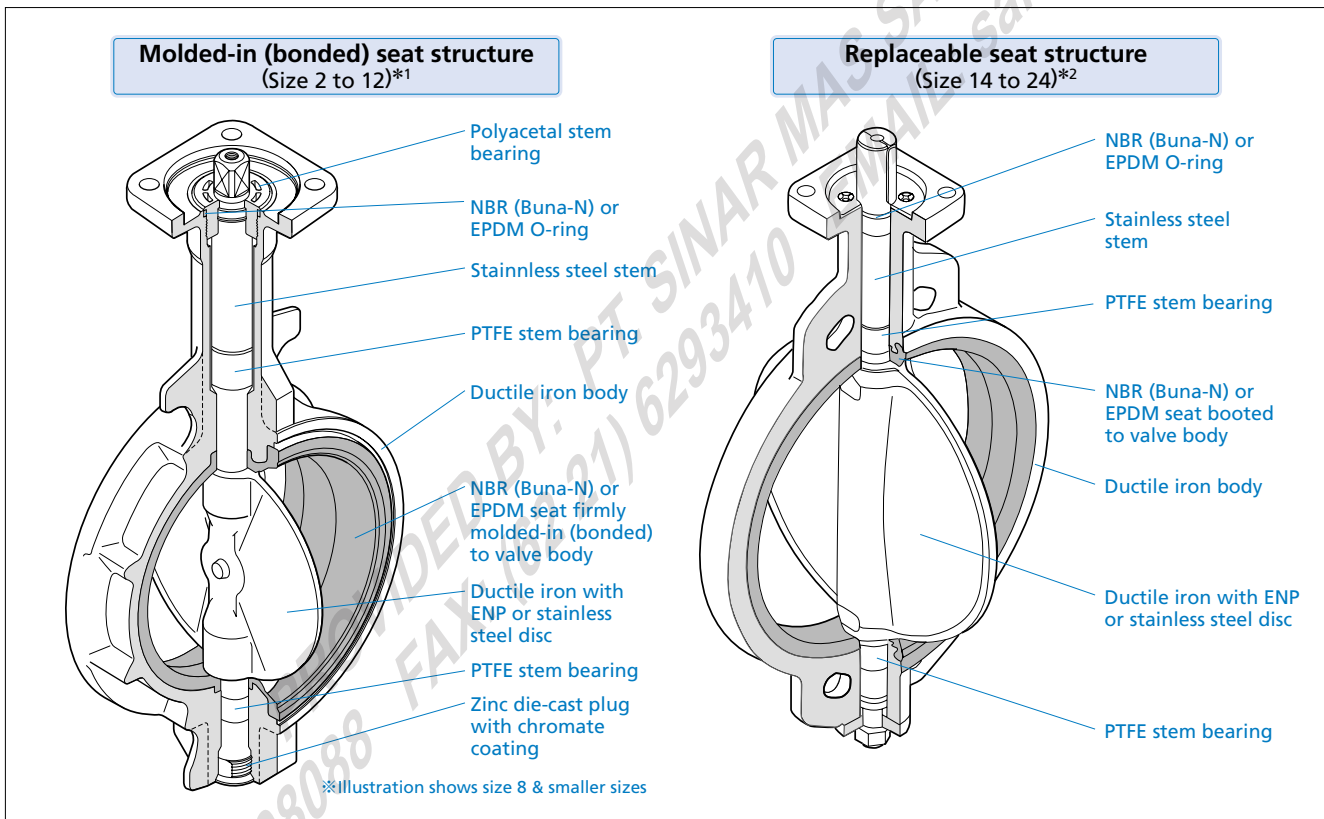

Non-peeling Seat-to-body Construction

Molded-in (bonded) seat structure is employed for size **2 to 12**. Larger sized valves are provided with replaceable seat. This non-peeling seat-to-body construction assures maintenance-free application for **high fluid velocity service*¹**, **vacuum service*²** and handling surging fluid velocity. It also guarantees peel-free valve mounting on pipelines.

*¹ **Maximum 4 meters/second for on-off service for valves up to size 12, and 3 meters/second for size 14 and larger.**

*² **Up to 30 torr. Vacuum service is option for size 14 and larger.**

Spherical design for Discs and Seats

Rubber seats are spherically designed where they contact top and bottom stems. This protects widely designed rubber seats from peeling or deformation for prolonged service life of valves. Thinly streamlined metal discs are the results of elaborate laboratory study to ultimately minimize the pressure loss.

Choice of Materials and Operating Devices

Choice among 4 disc and 2 seat materials and manual, pneumatic or electric valve operating devices makes service applications highly versatile.

Integral ISO 5211 Actuator Mounting Flange

Any pneumatic or electric valve actuators provided with ISO 5211 valve mounting flanges can be easily mounted for actuation of valves in the field.

Low Valve Operating Torque

Low operating torques are designed low for extension of valve service life and economic consideration in selection of valve operating devices.

Light-designed for Operation Efficiency

Designed much lighter than our conventional series for operation efficiency in piping

Emission-free Stem Sealing Mechanism

Prevention of external fluid leakage is maximized with a rubber O-ring assembled around the top stem and tight contact between spherically designed rubber seat and spherically designed top and bottom end of the disc.

Dew condensation prevention

Dew condensation prevention type is optionally available with heat insulating plate (size 2 to 6) or stainless steel stand (size 8 to 24).

Technical Specifications

Maximum Service Pressure

ASME 150 psi	1.03MPa (10.5kgf/cm ²)
ASME 200 psi	1.38MPa (14.1kgf/cm ²)
BS PN16	1.6 MPa (16 kgf/cm ²)
JIS 10K	0.98MPa (10 kgf/cm ²)
JIS 16K	1.57MPa (16 kgf/cm ²)

Body Material

Ductile iron	ASTM A536 Gr. 65-45-12 *1
---------------------	---------------------------

*1 JIS 10K design, size 14" & larger: Cast iron ASTM A126 Class B

Service Temperature Range

NBR (Buna-N) seat	0°C to +70°C
EPDM seat	-20°C to +130°C *2
Continuous service temperature range	0°C to +100°C

*2 There are some fluid type restrictions for the service at 130°C. Contact KITZ for the details.

Applicable Standards

Valve design	API 609, MSS-SP 67, EN 593, JIS B 2032
Face to face dimensions	API 609 Category A, MSS-SP 67 W-1 : Size 2 to 14 W-2 : Size 16 to 24 EN 558 20 Series, ISO 5752 20 Series, JIS B 2002 46 Series

Coupling Flanges

Wafer type	ASME Class 125/150 EN 1092 PN 10: DN 50 to DN 350, PN 16: All Sizes BS 10 Table D/Table E JIS 10K/16K
Lugged type	ASME Class 125/150 EN 1092 PN 10: DN 50 to DN 150, PN 16: All Sizes

Test Pressure (Hydrostatic)

ASME 150 psi	Shell test	1.55MPa (15.8kgf/cm ²)
	Seat test	1.14MPa (11.6kgf/cm ²)
ASME 200 psi	Shell test	2.07MPa (21.1kgf/cm ²)
	Seat test	1.52MPa (15.5kgf/cm ²)
BS PN16	Shell test	2.4 MPa (24.5kgf/cm ²)
	Seat test	1.76MPa (17.9kgf/cm ²)
JIS 10K	Shell test	1.47MPa (15 kgf/cm ²)
	Seat test	1.08MPa (11 kgf/cm ²)
JIS 16K	Shell test	2.36MPa (24 kgf/cm ²)
	Seat test	1.73MPa (17.6kgf/cm ²)

Flow Coefficient (Cv)

Size		Valve opening			
inch	mm	30°	45°	60°	90°
2	50	10	23	47	124
2 1/2	65	22	50	102	270
3	80	33	74	149	397
4	100	55	125	252	671
5	125	83	189	381	1013
6	150	126	286	576	1532
8	200	230	522	1050	2792
10	250	325	743	1514	4025
12	300	493	1123	2260	6010
14	350	617	1371	2829	7525
16	400	826	1787	3760	10080
18	450	1076	2441	4933	13120
20	500	1311	2969	6012	15990
24	600	1942	4449	8907	23690

Pressure Loss

(for handling static clean water with valve fully open)

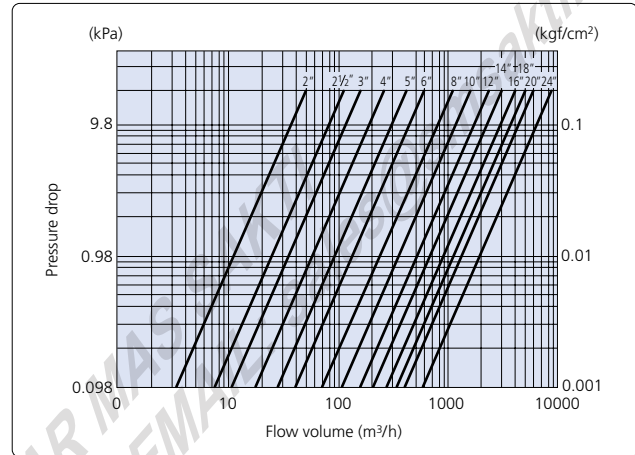

P-T Rating

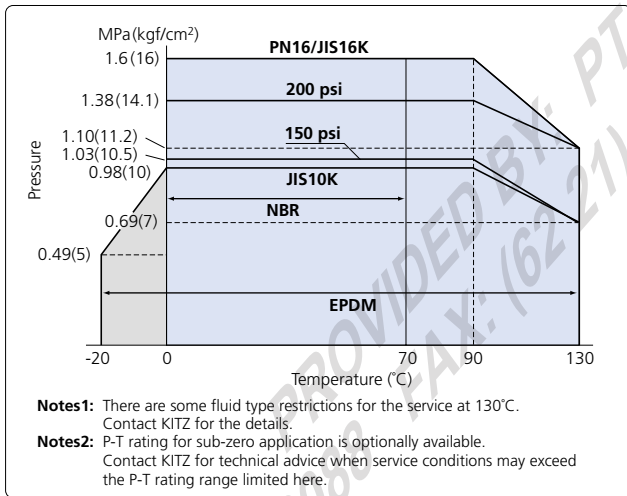

Flow Characteristics

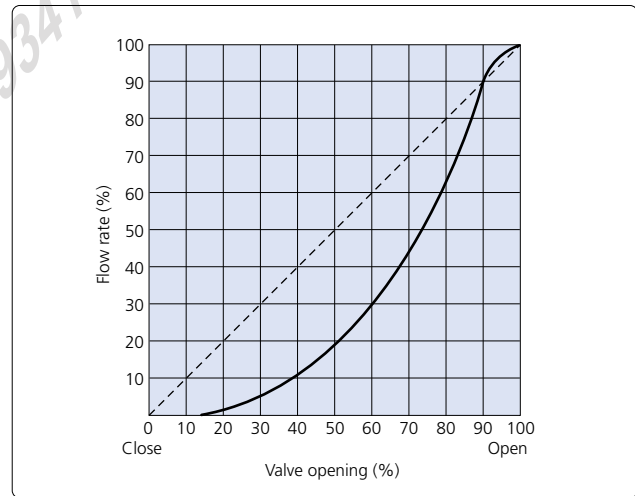

Standard Materials

Parts	Material	
Body	Ductile Iron	
	Cast Iron (JIS 10K design Size 14" to 24")	
Stem / Bottom stem	410 Stainless Steel (Size 14" to 24")	
	420 Stainless Steel (Size 16" to 24")	
Disc	Ductile Iron (Ni-plated) / 304SS / 316SS / Aluminum Bronze (See Explanation of Product Code)	
Seat / O-ring	NBR (Buna-N) / EPDM (See Explanation of Product Code)	
Bearing	Polyacetal / Glass Filled PTFE / Metal Backed PTFE	
Plug (Size 2" to 8")	Zinc die-cast (Chromate Coating)	
Operator	Lever	Aluminum Die-cast
	Gear	Aluminum Die-cast (Size 2" to 12") Cast-Iron (Size 14" to 24")
	Vertical gear	Cast-Iron

Wafer Type **Lever Operated**

ASME 150/200 psi Design

200DJ□□

EN PN16 Design

PN16DJ□□

JIS 10K Design

10DJ□□

JIS 16K Design

16DJ□□

□□ of product coding are disc and seat material coding

Please refer to page 1.

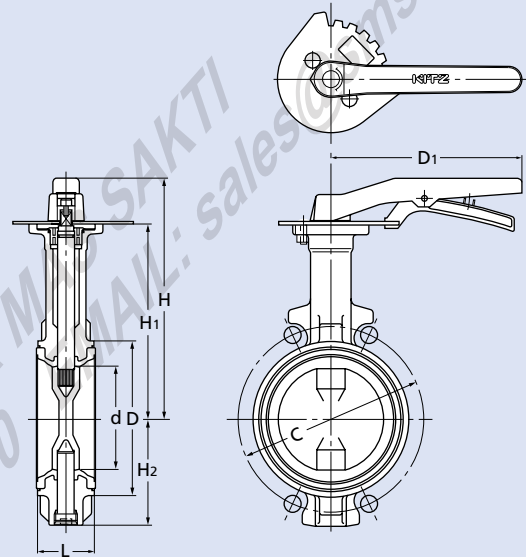

ASME 200 psi • EN PN16 • JIS 10K • JIS 16K Design Dimensions

(mm)

Nominal Size		d	H	H1	H2	L	D	C				D1
inch	mm							ASME 200	EN PN16	JIS 10K	JIS 16K	
2	50	50	191	147	67	43	90	120.5	125	120	120	180
2½	65	65	199	155	75	46	104	139.5	145	140	140	180
3	80	80	217	173	91	46	124	152.5	160	150	160	180
4	100	100	227	183	101	52	146	190.5	180	175	185	180
5	125	125	265	211	127	56	176	216	210	210	225	230
6	150	150	277	223	139	56	206	241.5	240	240	260	230
8	200	197	295	248	169	60	257	298.5	295	290	305	350

Wafer Type Gear Operated

ASME 150/200 psi Design

G-150/200DJ □□

EN PN16 Design

G-PN16DJ □□

JIS 10K Design

G-10DJ □□

JIS 16K Design

G-16DJ □□

□□ of product coding are disc and seat material coding

Please refer to page 1.

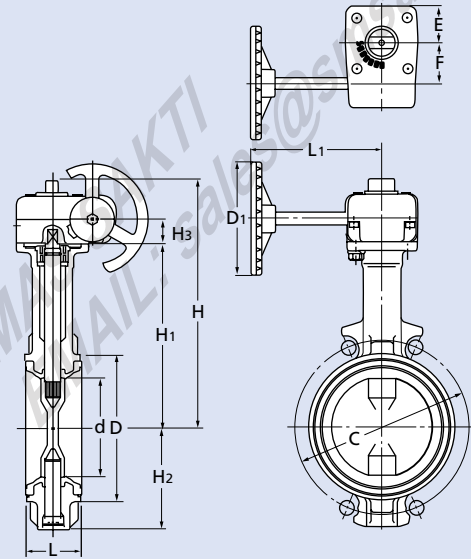

ASME 150/200 psi • JIS 10K Design Dimensions (mm)

Nominal Size	inch	mm	d	H	H1	H2	H3	L	D	C		D1		L1		E	F
										ASME 150/200	JIS 10K	ASME 150/200	JIS 10K	ASME 150/200	JIS 10K		
2	50	50	50	194	147	67	19	43	90	120.5	120	80	122	29	28		
2½	65	65	65	202	155	75	19	46	104	139.5	140	80	122	29	28		
3	80	80	80	236	173	91	24	46	124	152.5	150	110	135	36	40		
4	100	100	100	246	183	101	24	52	146	190.5	175	110	135	36	40		
5	125	125	125	274	211	127	24	56	176	216	210	110	150	36	40		
6	150	150	150	286	223	139	24	56	206	241.5	240	110	150	36	40		
8	200	197	197	325	248	169	32	60	257	298.5	290	170	180	51	63		
10	250	246	246	381	304	219	32	68	312	362	355	170	180	51	63		
12	300	295	295	406	329	244	32	78	364	432	400	170	180	51	63		
14	350	333	333	447	360	309	47	78	407	476.5	445	310	220	54	66		
16	400	385	385	502	415	348	47	102	466	539.5	510	310	220	54	66		
18	450	434	434	526	439	372	47	114	522	578	565	310	220	54	66		
20	500	482	482	587	488	423	60	127	575	635	620	500	360	68	89		
24	600	579	579	635	536	472	60	154	680	749.5	730	500	360	68	89		

*: ASME 200 psi for size 2 to 12, 150 psi for size 14 to 24.

EN PN16 • JIS 16K Design Dimensions (mm)

Nominal Size	inch	mm	d	H	H1	H2	H3	L	D	C		D1		L1		E	F
										EN PN16	JIS 16K	EN PN16	JIS 16K	EN PN16	JIS 16K		
2	50	50	50	194	147	67	19	43	90	125	120	80	122	29	28		
2½	65	65	65	202	155	75	19	46	104	145	140	80	122	29	28		
3	80	80	80	236	173	91	24	46	124	160	160	110	135	36	40		
4	100	100	100	246	183	101	24	52	146	180	185	110	135	36	40		
5	125	125	125	274	211	127	24	56	176	210	225	110	150	36	40		
6	150	150	150	286	223	139	24	56	206	240	260	110	150	36	40		
8	200	197	197	325	248	169	32	60	257	295	305	170	180	51	63		
10	250	246	246	381	304	219	32	68	312	355	380	250	250	51	63		
12	300	295	295	406	329	244	32	78	364	410	430	250	250	51	63		
14	350	333	333	461	360	309	60	78	407	470	480	500	360	68	89		
16	400	385	385	516	415	348	60	102	466	525	540	500	360	68	89		
18	450	434	434	540	439	372	60	114	522	585	605	500	360	68	89		
20	500	482	482	623	488	423	65	127	575	650	660	500	360	90	134		
24	600	579	579	671	536	472	65	154	680	770	770	500	410	90	134		

Wafer Type Vertical gear operated

ASME 150/200 psi Design

VG-150/200DJ □□

EN PN16 Design

VG-PN16DJ □□

JIS 10K Design

VG-10DJ □□

JIS 16K Design

VG-16DJ □□

□□ of product coding are disc and seat material coding

Please refer to page 1.

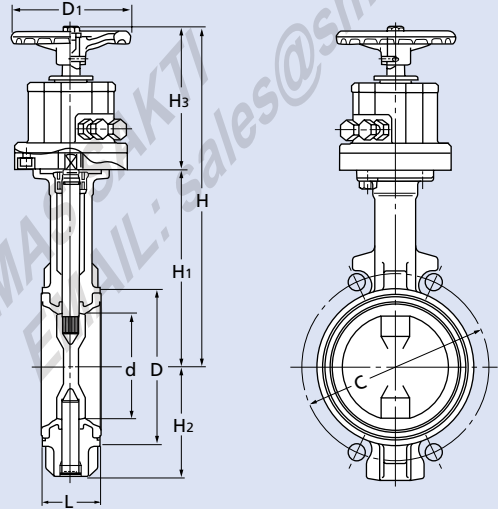

ASME 150/200 psi • EN PN16 • JIS 10K • JIS 16K Design Dimensions (mm)

Nominal Size		d	H		H1	H2	H3		L	D	C				D1
inch	mm		ASME 150/200 JIS 10K	EN PN16 JIS 16K			ASME 150/200 JIS 10K	EN PN16 JIS 16K			ASME 150/200	EN PN16	JIS 10K	JIS 16K	
2	50	50	270	147	67	123	43	90	120.5	125	120	120	110		
2½	65	65	278	155	75	123	46	104	139.5	145	140	140	110		
3	80	80	285	173	91	112	46	124	152.5	160	150	160	110		
4	100	100	295	183	101	112	52	146	190.5	180	175	185	110		
5	125	125	325	211	127	114	56	176	216	210	210	225	170		
6	150	150	337	223	139	114	56	206	241.5	240	240	260	170		
8	200	197	404	248	169	156	60	257	298.5	295	290	305	200		
10	250	246	461	304	219	157	68	312	362	355	355	380	310		
12	300	295	486	329	244	157	78	364	432	410	400	430	310		
14	350	333	569	360	309	209	78	407	476.5	470	445	480	360		
16	400	385	624	649	415	348	209	234	102	466	539.5	525	510	540	360
18	450	434	648	673	439	372	209	234	114	522	578	585	565	605	360
20	500	482	741	766	488	423	253	278	127	575	635	650	620	660	500
24	600	579	789	814	536	472	253	278	154	680	749.5	770	730	770	500

*: ASME 200 psi for size 2 to 12, 150 psi for size 14 to 24.

Vertical gear operated

Memo

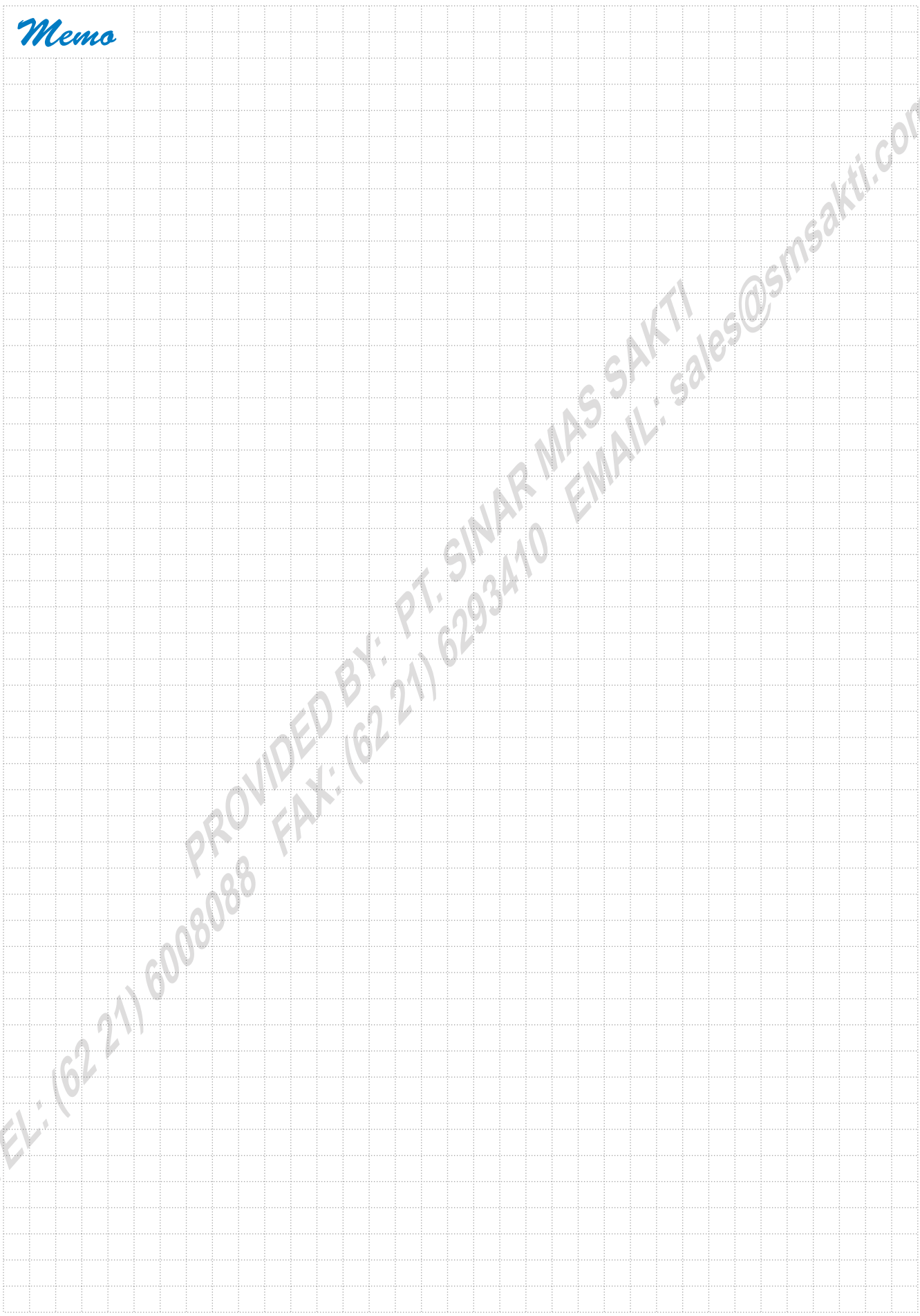

TEL: (62 21) 6008088 PROVIDED BY: PT. SINAR MAS SAKTI FAX: (62 21) 6293410 EMAIL: sales@smsakti.com

Lugged type **Lever Operated**

ASME 150/200 psi Design

200DJL □□

EN PN16 Design

PN16DJL □□

□□ of product coding are disc and seat material coding

Please refer to page 1.

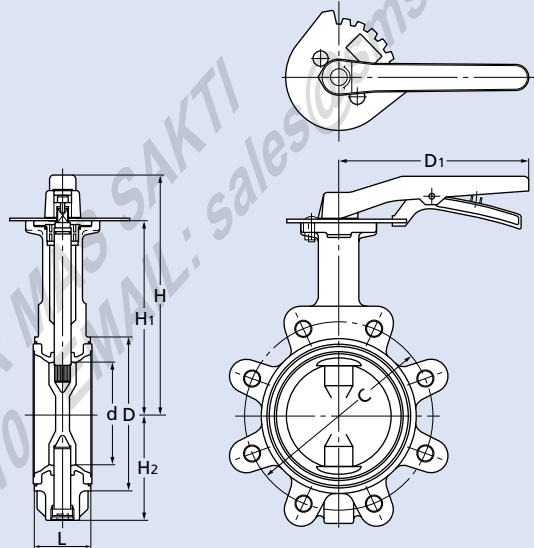

ASME 200 psi • EN PN16 Design Dimensions

(mm)

Nominal Size		d	H	H1	H2	L	D	C		D1
inch	mm							ASME 200	EN PN16	
2	50	50	191	147	67	43	90	120.5	125	180
2½	65	65	199	155	75	46	104	139.5	145	180
3	80	80	217	173	91	46	124	152.5	160	180
4	100	100	227	183	101	52	146	190.5	180	180
5	125	125	265	211	127	56	176	216	210	230
6	150	150	277	223	139	56	206	241.5	240	230
8	200	197	295	248	169	60	257	298.5	295	350

Lugged type Gear operated

ASME 150/200 psi Design

G-150/200DJL

EN PN16 Design

G-PN16DJL

□□ of product coding are disc and seat material coding

Please refer to page 1.

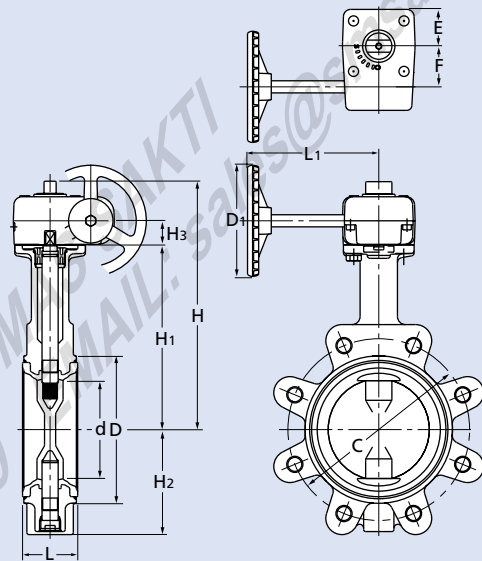

ASME 150/200 psi Design Dimensions (mm)

Nominal Size		d	H	H1	H2	H3	L	D	C	D1	L1	E	F
inch	mm												
2	50	50	194	147	67	19	43	90	120.5	80	122	29	28
2½	65	65	202	155	75	19	46	104	139.5	80	122	29	28
3	80	80	236	173	91	24	46	124	152.5	110	135	36	40
4	100	100	246	183	101	24	52	146	190.5	110	135	36	40
5	125	125	274	211	127	24	56	176	216	110	150	36	40
6	150	150	286	223	139	24	56	206	241.5	110	150	36	40
8	200	197	325	248	169	32	60	257	298.5	170	180	51	63
10	250	246	381	304	219	32	68	312	362	170	180	51	63
12	300	295	406	329	244	32	78	364	432	170	180	51	63
14	350	333	447	360	309	47	78	407	476.5	310	220	54	66
16	400	385	502	415	348	47	102	466	539.5	310	220	54	66
18	450	434	526	439	372	47	114	522	578	310	220	54	66
20	500	482	587	488	423	60	127	575	635	500	360	68	89
24	600	579	635	536	472	60	154	680	749.5	500	360	68	89

*: ASME 200 psi for size 2 to 12, 150 psi for size 14 to 24.

EN PN16 Design Dimensions (mm)

Nominal Size		d	H	H1	H2	H3	L	D	C	D1	L1	E	F
inch	mm												
2	50	50	194	147	67	19	43	90	125	80	122	29	28
2½	65	65	202	155	75	19	46	104	145	80	122	29	28
3	80	80	236	173	91	24	46	124	160	110	135	36	40
4	100	100	246	183	101	24	52	146	180	110	135	36	40
5	125	125	274	211	127	24	56	176	210	110	150	36	40
6	150	150	286	223	139	24	56	206	240	110	150	36	40
8	200	197	325	248	169	32	60	257	295	170	180	51	63
10	250	246	381	304	219	32	68	312	355	250	250	51	63
12	300	295	406	329	244	32	78	364	410	250	250	51	63
14	350	333	461	360	309	60	78	407	470	500	360	68	89
16	400	385	516	415	348	60	102	466	525	500	360	68	89
18	450	434	540	439	372	60	114	522	585	500	360	68	89
20	500	482	623	488	423	65	127	575	650	500	410	90	134
24	600	579	671	536	472	65	154	680	770	500	410	90	134

Bolting Data for Ductile Iron / Steel Flanges

Wafer type (Either type of below bolting is required)

Hexagon head bolt + Hexagon nut

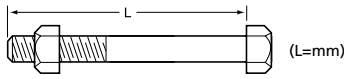

*Size 24" requires additional hexagon head bolts.

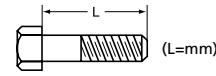

Hexagon head bolt + Hexagon nut (mm)																	
Flange		ANSI Class 125/150				EN PN10			EN PN16			JIS 10K			JIS 16K		
inch	mm	Size	L(inch/mm)	Number	Size	L	Number	Size	L	Number	Size	L	Number	Size	L	Number	
2	50	5/8	4.25	108	4	M16	105	4	M16	105	4	M16	95	4	M16	95	8
2 1/2	65	5/8	4.75	121	4	M16	105	4	M16	105	4	M16	105	4	M16	105	8
3	80	5/8	4.75	121	4	M16	105	8	M16	105	8	M16	105	8	M20	110	8
4	100	5/8	5.00	127	8	M16	115	8	M16	115	8	M16	110	8	M20	120	8
5	125	3/4	5.25	133	8	M16	115	8	M16	115	8	M20	120	8	M22	125	8
6	150	3/4	5.50	140	8	M20	120	8	M20	120	8	M20	125	8	M22	130	12
8	200	3/4	5.75	146	8	M20	130	8	M20	130	12	M20	130	12	M22	140	12
10	250	7/8	6.50	165	12	M20	140	12	M24	150	12	M22	150	12	M24	150	12
12	300	7/8	7.00	178	12	M20	155	12	M24	160	12	M22	160	16	M24	170	16
14	350	1	7.50	191	12	M20	155	16	M24	170	16	M22	160	16	M30X3	180	16
16	400	1	8.50	216	16	—	—	—	M27	200	16	M24	190	16	M30X3	210	16
18	450	1 1/8	9.25	235	16	—	—	—	M27	210	20	M24	210	20	M30X3	230	20
20	500	1 1/8	10.25	260	20	—	—	—	M30	230	20	M24	220	20	M30X3	250	20
24	600	1 1/4	11.75	298	20	—	—	—	M33	270	20	M30	260	20	M36X3	290	20
													70*	8*		90*	8*

Stud bolt + Hexagon nut

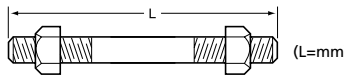

*Size 24" requires additional hexagon head bolts.

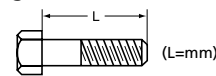

Stud head bolt + Double hexagon nut (mm)																	
Flange		ANSI Class 125/150				EN PN10			EN PN16			JIS 10K			JIS 16K		
inch	mm	Size	L(inch/mm)	Number	Size	L	Number	Size	L	Number	Size	L	Number	Size	L	Number	
2	50	5/8	5.00	127	4	M16	125	4	M16	125	4	M16	115	4	M16	120	8
2 1/2	65	5/8	5.25	133	4	M16	130	4	M16	130	4	M16	120	4	M16	120	8
3	80	5/8	5.25	133	4	M16	130	8	M16	130	8	M16	120	8	M20	140	8
4	100	5/8	5.75	146	8	M16	135	8	M16	135	8	M16	130	8	M20	140	8
5	125	3/4	6.25	159	8	M16	140	8	M16	140	8	M20	145	8	M22	150	8
6	150	3/4	6.50	165	8	M20	145	8	M20	145	8	M20	150	8	M22	160	12
8	200	3/4	6.75	171	8	M20	155	8	M20	150	12	M20	155	12	M22	160	12
10	250	7/8	7.50	191	12	M20	170	12	M24	170	12	M22	170	12	M24	180	12
12	300	7/8	8.00	203	12	M20	185	12	M24	190	12	M22	180	16	M24	190	16
14	350	1	8.75	222	12	M20	185	16	M24	190	16	M22	180	16	M30X3	210	16
16	400	1	9.75	248	16	—	—	—	M27	220	16	M24	220	16	M30X3	240	16
18	450	1 1/8	10.75	273	16	—	—	—	M27	240	20	M24	230	20	M30X3	260	20
20	500	1 1/8	11.50	292	20	—	—	—	M30	260	20	M24	250	20	M30X3	280	20
24	600	1 1/4	13.25	337	20	—	—	—	M33	300	20	M30	290	20	M36X3	320	20
													70*	8*		90*	8*

Lugged type

Hexagon head bolt (mm)											
Flange		ANSI Class 125/150			EN PN10			EN PN16			
inch	mm	Size	L(inch/mm)	Number	Size	L	Number	Size	L	Number	
2	50	5/8	1.375	35	8	M16	38	8	M16	38	8
2 1/2	65	5/8	1.500	38	8	M16	40	8	M16	40	8
3	80	5/8	1.625	41	8	M16	40	16	M16	40	16
4	100	5/8	1.875	48	16	M16	40	16	M16	40	16
5	125	3/4	1.875	48	16	M16	40	16	M16	40	16
6	150	3/4	2.000	51	16	M20	45	16	M20	45	16
8	200	3/4	2.125	54	16	—	—	—	M20	45	24
10	250	7/8	2.375	60	24	—	—	—	M24	53	24
12	300	7/8	2.625	67	24	—	—	—	M24	60	24
14	350	1	2.750	70	24	—	—	—	M24	60	32
16	400	1	3.000	76	32	—	—	—	M27	70	32
18	450	1 1/8	3.375	86	32	—	—	—	M27	75	40
20	500	1 1/8	3.500	89	40	—	—	—	M30	80	40
24	600	1 1/4	4.000	102	40	—	—	—	M33	90	40

Hexagon head bolts.

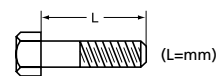

Precautions for Trouble-free Operation of KITZ Butterfly Valves

Valve Selection

1. Ensure to select a valve with design specifications which meet the fluid type and the pressure and temperature conditions required.
2. Lubricants are applied to discs, rubber seats and PTFE seats as standard to protect their surfaces.
Oil-free treated types are available as option. Contact KITZ Corporation or its local distributors for the details.
3. Contact KITZ Corporation or its local distributors for service with pulverulent bodies.

Storage and Handling

Valves must be stored in dry, clean and corrosion-free environment with no direct exposure to the sun, leaving valves open by 10° for prevention of permanent distortion of resilient seats. Refrain from overloading valves and their actuators, such as storing them in piles or placing other objects on them.

Mounting on Pipelines

1. Valves must be mounted on flanges only after flanges have been welded to pipes and cooled down to the atmospheric temperature. Otherwise, welding heat may affect the quality of resilient seats.
2. Edges of welded flanges must be machined for smooth surface finish so that they may not damage resilient seats during valve mounting. Flange faces must be free from damage or deformation, and be cleaned to remove rust or any other foreign objects so that there will be no concern of external leakage through valve and flange connections. Gaskets are not required for mounting KITZ DJ series butterfly valves.
3. Clean flanges and pipe bores to thoroughly remove welding spatters, scales and other foreign objects which may have been left inside.
4. Accurate centering of each couple of upstream and downstream pipes is essential for trouble-free operation of valves mounted between them. Incorrect centering shown in **Fig. 1** must be by all means avoided.
5. For valve mounting, set jack bolts under the pipes for flat support at the same height, and adjust the flange-to-flange distance so that some 6 mm to 10 mm room may be allowed beside the both sides of the valve body. Remember that valves here must be left open only by 10° from the fully closed position.
6. Set two bolts into the lower mounting guides of a valve and mount it carefully so that flange faces may not damage resilient seats. (**Fig. 2**)
7. Then set another two bolts into the upper mounting guides of a valve, ensuring the correct centering between pipes and the valve.
8. Trially open the valve to check to see if there is no disturbing contact between the valve disc and the flanges.
9. Remove the jack bolts, set all bolts around the valve body and tighten them alternately and diagonally till the flanges contact the valve body (**Fig. 3 and 4**).

Fig.1

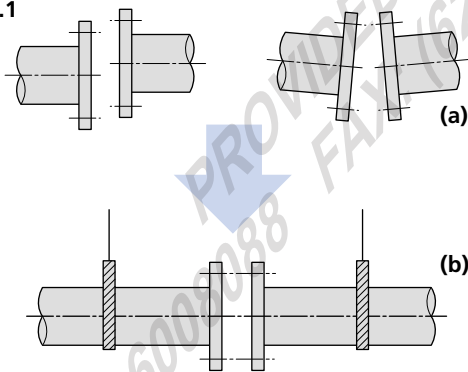

Fig.2

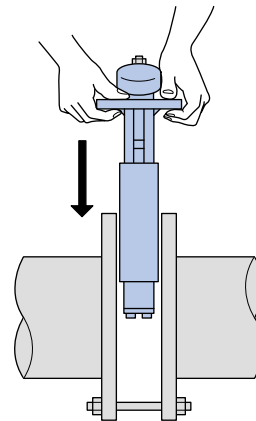

Fig.3

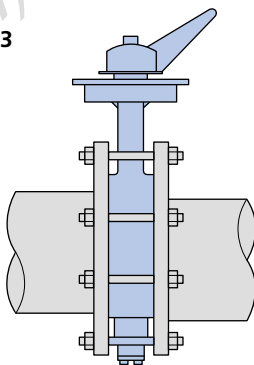
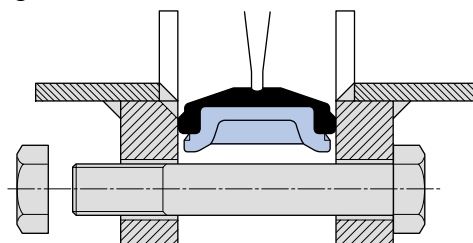

Fig.4



10. For mounting actuated valves, provide valve supports to prevent bending of valve necks and reduce valve and pipe vibration.
11. Don't step on valve necks or valve handwheels.
12. Don't mount valves of DN350 and larger with their operations upside down.
13. Don't mount butterfly valves directly to check valves or pumps, which may cause damage to them by the disc contacts.
14. Don't mount valves to downstream sides of elbows, reducers or regulating valves where fluid velocity changes. It is recommended to install valves approx-imately 10 times of the valve nominal sizes away from them for such cases.
15. Mount valves taking consideration of the effects which discs are given by fluid velocity or pressure chages in the pipings. Refer to the illustrations. **(Fig.5)**
Contact KITZ Corporation or its local distributors for the details.

Valve Operation

1. Valves equipped with manual operators such as levers, and handles of gears must be ONLY MANUALLY operated. Application of an excessive external force to operate valves may result in malfunction of valves and their operators.
 2. Ensure to fully open valves before a loop test of the piping system is carried out with line pressure higher than the nominal pressure of tested valves.
3. Never use closed valves in place of blind flanges.
 3. When valves need to be dismantled from pipes for maintenance or any other cause, ensure to thoroughly releave the line pressure beforehand. Loosening piping bolts under line pressure causes a danger. Any residual fluid left inside the pipeline must be completely drained.
 4. Users should contact KITZ Corporation or its local distributors for technical advice, when valves should be continuously pressurized while left open by 30° or less.
 5. Don't use position indicators to operate valves, or overload position indicators. This may cause damage to indicators.
 6. Ensure to use blind flanges when butterfly valves are mounted at the end of pipelines.
 7. Standard actuators are referenced in this catalog for actuated valve operation. Contact KITZ Corporation or its local distributors for mounting optional actuators.
 8. Contact KITZ Corporation for service at hopper or pump outlets.
 9. Avoid touching gear operators and actuator stopper bolts accidentally.
 10. It is recommended to perform periodical inspection for
 - Making sure of valve opening degree
 - Checking loosened bolts and leakage at each connection
 - Checking vibration and noise
 11. Refer to instruction manual for other precautions. Also refer to actuator catalogs and instruction manuals for actuated valves.

Fig.5

● Mounting to bent pipe

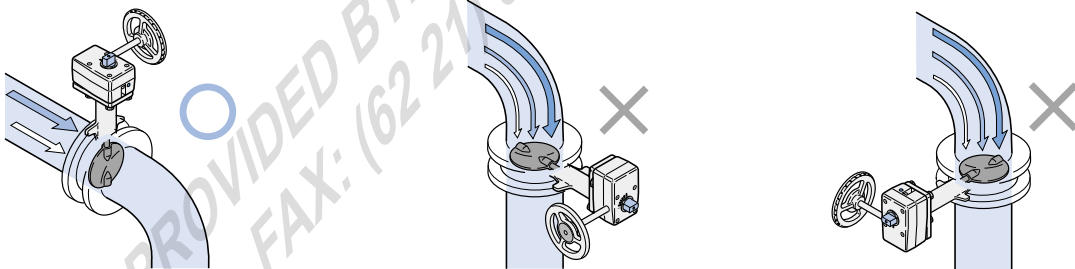

● Mounting to pump outlet

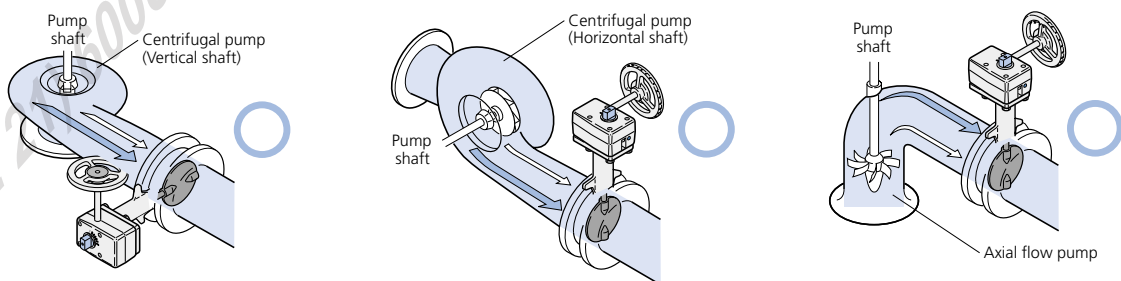

Memo

PROVIDED BY: PT. SINAR MAS SAKTI
TEL: (62 21) 6008088 FAX: (62 21) 6293410 EMAIL: sales@smsakti.com

CAUTION

Pressure-temperature ratings and other performance data published in this catalog have been developed from our design calculation, in-house testing, field reports provided by our customers and/or published official standards or specifications. They are good only to cover typical applications as a general guideline to users of KITZ products introduced in this catalog.

For any specific application, users are kindly requested to contact KITZ Corporation for technical advice, or to carry out their own study and evaluation for proving suitability of these products to such an application. Failure to follow this request could result in property damage and/or personal injury, for which we shall not be liable.

While this catalog has been compiled with the utmost care, we assume no responsibility for errors, impropriety or inadequacy. Any information provided in this catalog is subject to from-time-to-time change without notice for error rectification, product discontinuation, design modification, new product introduction or any other cause that KITZ Corporation considers necessary. This edition cancels all previous issues.

NOTICE

If any products designated as strategic material in the Foreign Exchange and Foreign Trade Law, Cabinet Order Concerning Control of Export Trade, Cabinet Order Concerning Control of Foreign Exchange and other related laws and ordinances ("Foreign Exchange Laws") are exported to any foreign country or countries, an export license issued by the Japanese Government will be required under the Foreign Exchange Laws.

Further, there may be cases where an export license issued by the government of the United States or other country will be required under the applicable export-related laws and ordinances in such relevant countries.

The contract shall become effective subject to that a relevant export license is obtained from the Japanese Government.

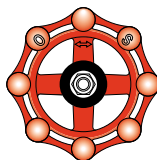

*A chrysanthemum-handle is a symbol of KITZ,
the brand of valve reliability*

ISO 9001 certified since 1989

KITZ
KITZ CORPORATION

1-10-1, Nakase, Mihama-ku, Chiba 261-8577, Japan
International Sales Dept. Phone : 81-43-299-1730, 1732 and 1733
Fax : 81-43-299-0121

— Distributed by —